

# Nitrogen punching unit with removable and mouldable stripper

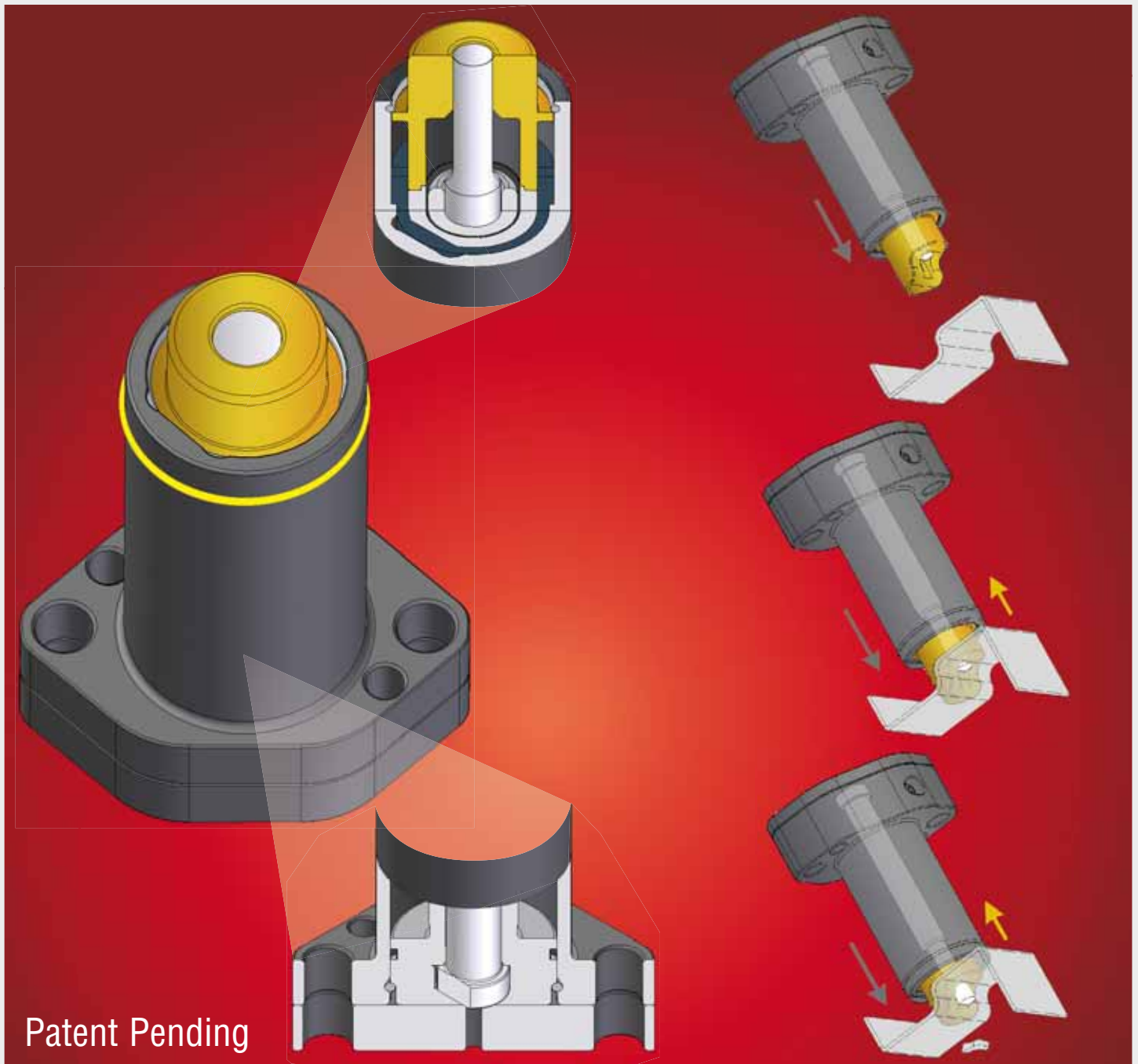

- STRIPPER HEAD REMOVABLE AND MOULDABLE
- EASY POSITIONING
- HIGH AND ADJUSTABLE HOLDING AND STRIPPING FORCE
- COMPACT DIMENSIONS
- SUITABLE FOR ISO 8020 SHOULDER STYLE PUNCH
- DOESN'T REQUIRE THE USE OF STANDARD RETAINER
- IDEAL FOR COMBINED USE WITH CAM UNIT

# Nitrogen punching unit with removable and mouldable stripper



## 90 mm shoulder style punch length

### Short stripper head

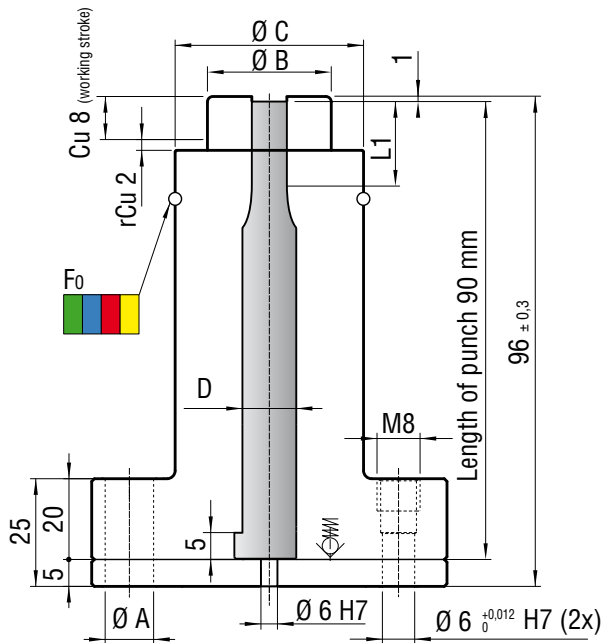

### Long stripper head

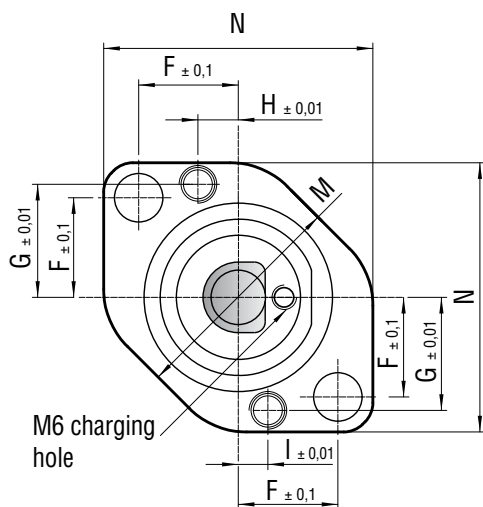
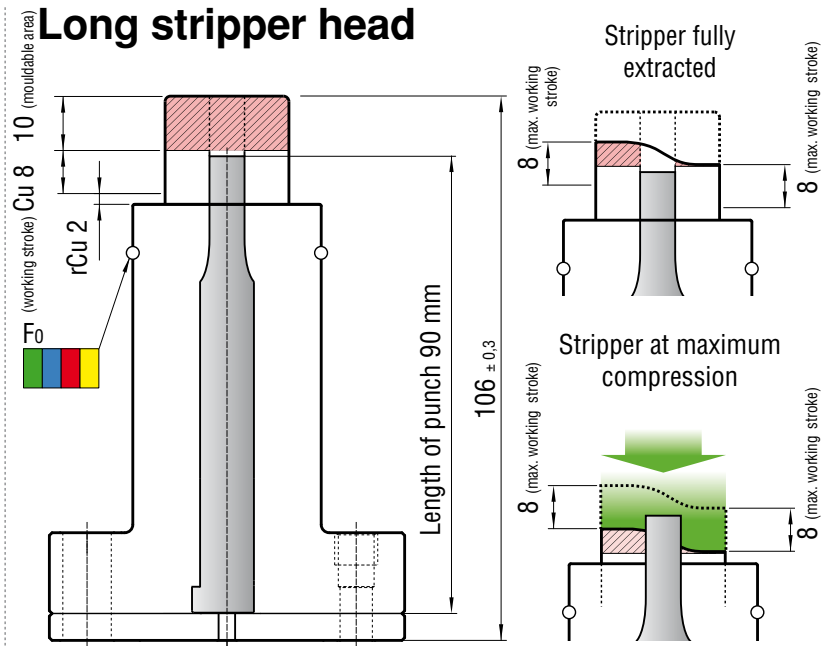

- ⚠ The short stripper head is recommended for flat piercing. Any moulded contour of the stripper head will cause a loss of working stroke.
- ⚠ The long stripper head is recommended for piercing where it is required a moulded contour of the stripper. The mouldable area of the stripper is 10 mm long and shall be machined by the user.
- ⚠ **IMPORTANT**  
The maximum working stroke of the stripper head is always **8 mm**. The maximum working stroke of the stripper head shall be always calculated from the first point of contact of the stripper with the working area of the sheet.
- ⚠ Special Springs' nitrogen punching unit with removable and mouldable stripper head is designed to fit ISO 8020 shoulder style punch standard.
- ⚠ The supply of the nitrogen punching unit stripper head always includes the punch guiding shape built-in the stripper, if not otherwise required. A bottom hardened counter plate is included. See how to order examples.

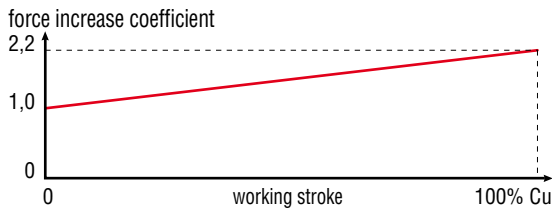

| Nitrogen punching unit code | D ISO 8020 | B  | C  | Cu | rCu* | A       | F  | G    | H  | I  | M  | N  | L1   | S**             | F <sub>0</sub>            | F <sub>0</sub>            | F <sub>0</sub>            | F <sub>0</sub>             |
|-----------------------------|------------|----|----|----|------|---------|----|------|----|----|----|----|------|-----------------|---------------------------|---------------------------|---------------------------|----------------------------|
|                             |            |    |    |    |      |         |    |      |    |    |    |    |      |                 | daN ±5% (25 bar at 20° C) | daN ±5% (50 bar at 20° C) | daN ±5% (75 bar at 20° C) | daN ±5% (100 bar at 20° C) |
| short and long stripper     | mm         | mm | mm | mm | mm   | mm      | mm | mm   | mm | mm | mm | mm | mm   | cm <sup>2</sup> | GR                        | BU                        | RD                        | YW                         |
| <b>3L P01A</b> (GR/BU ...)  | 10         | 23 | 35 | 8  | 2    | 9 (2x)  | 19 | 22   | 7  | 5  | 42 | 55 | ≥ 19 | 5,05            | 125                       | 255                       | 380                       | 505                        |
| <b>3L P02A</b> (GR/BU ...)  | 13         | 29 | 43 | 8  | 2    | 9 (2x)  | 24 | 27   | 7  | 5  | 50 | 65 | ≥ 19 | 6,95            | 175                       | 350                       | 520                       | 695                        |
| <b>3L P03A</b> (GR/BU ...)  | 16         | 29 | 43 | 8  | 2    | 9 (2x)  | 24 | 27   | 7  | 5  | 50 | 65 | ≥ 19 | 6,95            | 175                       | 350                       | 520                       | 695                        |
| <b>3L P04A</b> (GR/BU ...)  | 20         | 40 | 58 | 8  | 2    | 11 (2x) | 28 | 32,5 | 13 | 11 | 64 | 78 | ≥ 19 | 11,6            | 290                       | 580                       | 870                       | 1160                       |
| <b>3L P05A</b> (GR/BU ...)  | 25         | 40 | 58 | 8  | 2    | 11 (2x) | 28 | 32,5 | 13 | 11 | 64 | 78 | ≥ 25 | 11,6            | 290                       | 580                       | 870                       | 1160                       |
| <b>3L P06A</b> (GR/BU ...)  | 32         | 48 | 67 | 8  | 2    | 13 (2x) | 31 | 37   | 14 | 12 | 74 | 85 | ≥ 25 | 13,85           | 345                       | 695                       | 1040                      | 1390                       |
| <b>3L P07A</b> (GR/BU ...)  | 40         | 60 | 81 | 8  | 2    | 13 (2x) | 36 | 42,5 | 21 | 19 | 90 | 96 | ≥ 25 | 18,85           | 470                       | 940                       | 1410                      | 1880                       |

All sizes in mm.

\* rCu reserve of stroke

\*\* S piston working size

# Nitrogen punching unit with removable and mouldable stripper

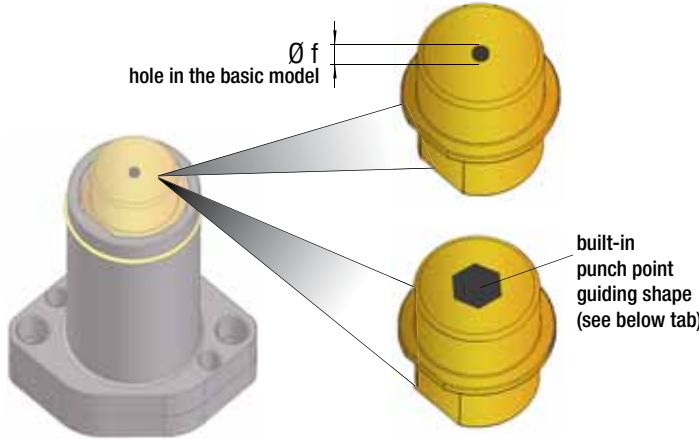

- The stripper head can also be supplied separately from the nitrogen punching unit. It can be supplied with or without (basic model) punch point guiding shape built-in.
- Geometry size and tolerance of the built-in punch guiding shape is always referred to the nominal punch size.
- Radial clearance between punch and punch point guiding hole is max. 0,1 mm.

| Reference to nitrogen punching unit code | $\varnothing$ punch mm | Short model stripper head<br>punch length = 90 mm |                    | Long model stripper head<br>punch length = 90 mm |                    |
|------------------------------------------|------------------------|---------------------------------------------------|--------------------|--------------------------------------------------|--------------------|
|                                          |                        | code                                              | $\varnothing f$ mm | code                                             | $\varnothing f$ mm |
| 3L P01A                                  | 10                     | 42 S 01                                           | 1,5                | 42 S 02                                          | 1,5                |
| 3L P02A                                  | 13                     | 42 S 03                                           | 3                  | 42 S 04                                          | 3                  |
| 3L P03A                                  | 16                     | 42 S 03                                           | 3                  | 42 S 04                                          | 3                  |
| 3L P04A                                  | 20                     | 42 S 07                                           | 3                  | 42 S 08                                          | 3                  |
| 3L P05A                                  | 25                     | 42 S 07                                           | 3                  | 42 S 08                                          | 3                  |
| 3L P06A                                  | 32                     | 42 S 11                                           | 3                  | 42 S 12                                          | 3                  |
| 3L P07A                                  | 40                     | 42 S 13                                           | 3                  | 42 S 14                                          | 3                  |

**T**

**A**

**R**

**K**

**F**

**L**

**D**

**E**

**C**

**S**

**H**

**J**

*Other shapes upon request*

**Punch point standard tolerance**

Round P  $\begin{matrix} +0,01 \\ -0,00 \end{matrix}$  0,01 P su D

Shape P, W  $\pm 0,01$  0,02 P su D



The punch is not included!

**How to order only the nitrogen unit** Example: 5 3L P04 YW

|          |                    |                         |
|----------|--------------------|-------------------------|
| <b>5</b> | <b>3L P04A</b>     | <b>YW</b>               |
| Quantity | Nitrogen unit code | Initial stripping force |

**How to order the nitrogen punching unit with punch point guiding shape built-in the stripper head** Example: 5 3L P04 YW 42 S 08 A P=... W=...

|          |                    |                         |                     |                                      |                                    |
|----------|--------------------|-------------------------|---------------------|--------------------------------------|------------------------------------|
| <b>5</b> | <b>3L P04A</b>     | <b>YW</b>               | <b>42 S 08</b>      | <b>A</b>                             | <b>P =... W =...</b>               |
| Quantity | Nitrogen unit code | Initial stripping force | Stripper head model | Form of punch point guiding built-in | Nominal sizes of punch point in mm |

**How to order only the stripper head with punch point guiding built-in** Example: 5 42 S 08 A P=... W=...

|          |                     |                                      |                                    |
|----------|---------------------|--------------------------------------|------------------------------------|
| <b>5</b> | <b>42 S 08</b>      | <b>A</b>                             | <b>P =... W =...</b>               |
| Quantity | Stripper head model | Form of punch point guiding built-in | Nominal sizes of punch point in mm |

**How to order only the stripper head without punch point guiding shape built-in (basic model)** Example: 5 42 S 08

|          |                     |
|----------|---------------------|
| <b>5</b> | <b>42 S 08</b>      |
| Quantity | Stripper head model |





# Clamp jig for moulding the stripper head



**!** To build-in the punch point guiding shape and/or contour the stripper head it is required to remove the stripper head from the nitrogen unit body.  
 The clamp jig is always re-usable.  
 Size, fixing and orientation of the anti-rotation correspond to the same of the nitrogen unit body.

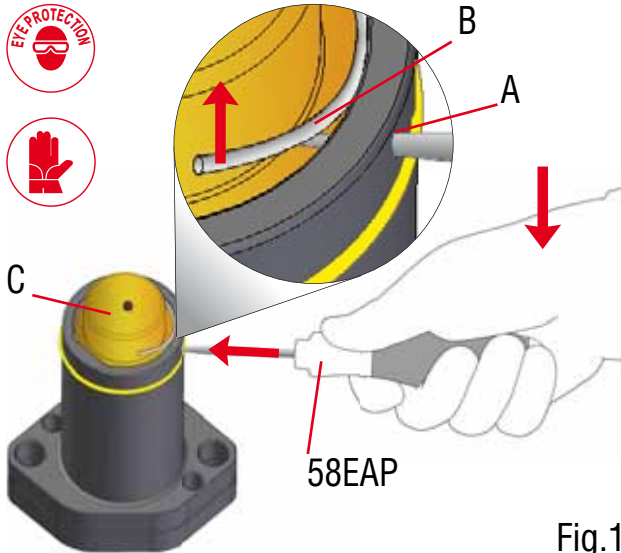

Fig.1

To remove the stripper head C, press and lift up the C-ring B through the hole A. Tool required 58EAP.

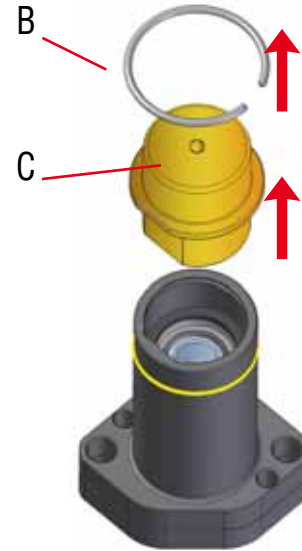

Fig.2

Remove the C-ring B from the groove and take the stripper head C out of the unit body.

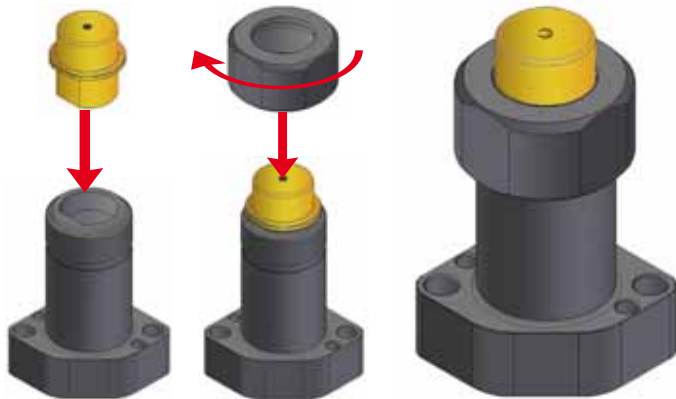

Fig.3

Select the appropriate model of clamp jig and position the stripper head into the lodging hole. Screw and lock the retaining nut.

Fig.4

Position and lock the clamp jig on the machine tool, wire EDM and/or tool plate and proceed with the required machining. After that re-assemble the stripper head on the nitrogen unit body following the reverse procedure.

## Examples of moulded contour stripper heads

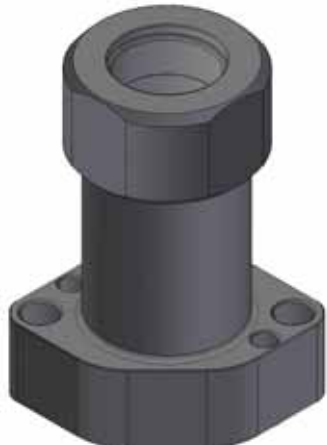
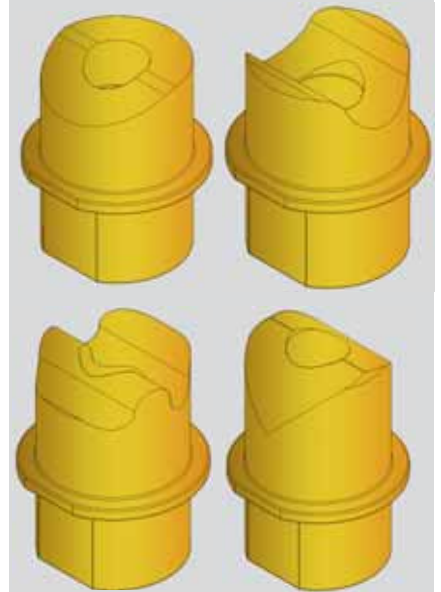

| Reference to nitrogen unit code | Stripper head clamp jig code |
|---------------------------------|------------------------------|
| 3L P01A (GR/BU ...)             | 3L MP01A                     |
| 3L P02A (GR/BU ...)             | 3L MP02A                     |
| 3L P03A (GR/BU ...)             | 3L MP02A                     |
| 3L P04A (GR/BU ...)             | 3L MP04A                     |
| 3L P05A (GR/BU ...)             | 3L MP04A                     |
| 3L P06A (GR/BU ...)             | 3L MP06A                     |
| 3L P07A (GR/BU ...)             | 3L MP07A                     |

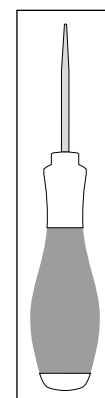

Cod. 58EAP

Retaining C-ring removal tool

# Nitrogen punching unit with removable and mouldable stripper



Stripper head retaining C-ring

Removable and mouldable stripper head.  
Basic model with 3 mm hole.



Removable and mouldable stripper head with punch point guiding shape built-in.

Force identification color ring



Nitrogen and shoulder style punch retainer unit.



Hardened bottom counter plate

## Discharging and charging devices

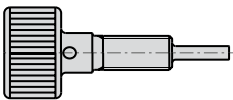

Discharging device **Cod. DDS-M6/3**

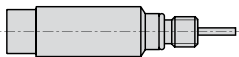

Charging adapter **Cod. ADM08** (included in the Cod. 39DMA set)  
To be used in combination with units Cod. 39DMCILA + Cod. 39DMCPVA.  
For more details see: Nitrogen cylinders catalogue.



Cejin male quick fit adapter for direct charging **Cod. QDFV02**  
To be used in combination with unit Cod. 39DMCPVA only.  
For more details see: Nitrogen cylinders catalogue.

Special Springs S.r.l. via Brega, 216 36027 Rosà (VI) ITALY  
tel. ++39 0424 539181  
fax ++39 0424 898230  
info@specialsprings.com www.specialsprings.com

9800G05002010

